

Half Bridge IGBT Module

电气特性:

- 1700V 沟槽栅/场终止工艺
1700V trench gate/field termination process
- 低开关损耗
Low switching losses
- Vcesat 正温度系数
Vcesat has a positive temperature coefficient

典型应用:

- 大功率变流器
Power Conversion System
- SVG
Static Var Generator
- 风力发电机
Wind Generatoren

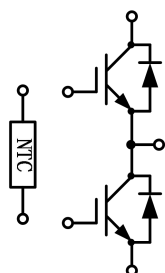

$V_{CES} = 1700V$, $I_{C\ nom} = 300A$ / $I_{CRM} = 600A$

IGBT, 逆变器 / IGBT, Inverter

最大额定值 / Maximum Ratings

Parameter	Conditions	Symbol	Value	Unit
集电极-发射极电压 Collector-Emitter voltage	$T_{vj} = 25^{\circ}C$	V_{CES}	1700	V
连续集电极直流电流 Continuous DC collector current	$T_C = 100^{\circ}C$, $T_{vj\ max} = 175^{\circ}C$	$I_{C\ nom}$	300	A
集电极重复峰值电流 Repetitive peak collector current	$t_p = 1\ ms$	I_{CRM}	600	A
总功率损耗 Total power dissipation	$T_C = 25^{\circ}C$, $T_{vj\ max} = 175^{\circ}C$	P_{tot}	2100	W
栅极-发射极电压 Gate emitter voltage		V_{GE}	± 20	V

特征值 / Characteristic Values

Parameter	Conditions	Symbol	Value			Unit
			Min.	Typ.	Max.	
集电极-发射极饱和电压 Collector-Emitter saturation voltage	$V_{GE}=15V, I_C=300A$ $V_{GE}=15V, I_C=300A$ $V_{GE}=15V, I_C=300A$	$T_{vj}=25^{\circ}C$ $T_{vj}=125^{\circ}C$ $T_{vj}=150^{\circ}C$	V_{CEsat}	1.98 2.38 2.48	2.80	V
栅极-发射极阈值电压 Gate-Emitter threshold voltage	$I_C=12mA, V_{GE}=V_{CE}$	$T_{vj}=25^{\circ}C$	$V_{GE(th)}$	4.90	5.60	6.10
栅电荷 Gate charge	$V_{GE}=-15V \dots +15V$		Q_G	2.12		μC
内部栅极电阻 Internal gate resistor	$T_{vj}=25^{\circ}C$		R_{Gint}	2.50		Ω
输入电容 Input capacitance	$f=100KHz, V_{CE}=25V, V_{GE}=0V$	$T_{vj}=25^{\circ}C$	C_{ies}	29.26		nF
反向传输电容 Reverse transfer capacitance			C_{res}	0.88		
集电极-发射极截止电流 Collector-emitter cut-off current	$V_{CE}=1700V, V_{GE}=0V$	$T_{vj}=25^{\circ}C$	I_{CES}		2	mA
栅极-发射极漏电流 Gate-emitter leakage current	$V_{CE}=0V, V_{GE}=20V$	$T_{vj}=25^{\circ}C$	I_{GES}		200	nA
开通延迟时间 Turn-on delay time	$I_C=300A, V_{CE}=900V$ $V_{GE}=\pm 15V, R_G=3.3\Omega$ (电感负载) / (inductive load)	$T_{vj}=25^{\circ}C$ $T_{vj}=125^{\circ}C$ $T_{vj}=150^{\circ}C$	t_{don}	222 241 250		ns
上升时间 Rise time	$I_C=300A, V_{CE}=900V$ $V_{GE}=\pm 15V, R_G=3.3\Omega$ (电感负载) / (inductive load)	$T_{vj}=25^{\circ}C$ $T_{vj}=125^{\circ}C$ $T_{vj}=150^{\circ}C$	t_r	78 90 93		
关断延迟时间 Turn-off delay time	$I_C=300A, V_{CE}=900V$ $V_{GE}=\pm 15V, R_G=3.3\Omega$ (电感负载) / (inductive load)	$T_{vj}=25^{\circ}C$ $T_{vj}=125^{\circ}C$ $T_{vj}=150^{\circ}C$	t_{doff}	443 490 508		
下降时间 Fall time	$I_C=300A, V_{CE}=900V$ $V_{GE}=\pm 15V, R_G=3.3\Omega$ (电感负载) / (inductive load)	$T_{vj}=25^{\circ}C$ $T_{vj}=125^{\circ}C$ $T_{vj}=150^{\circ}C$	t_f	311 335 339		
开通损耗能量 (每脉冲) Turn-on energy loss per pulse	$I_C=300A, V_{CE}=900V$ $V_{GE}=\pm 15V, R_G=3.3\Omega$ $di/dt=2500A/\mu s(T_{vj}=150^{\circ}C)$ (电感负载) / (inductive load)	$T_{vj}=25^{\circ}C$ $T_{vj}=125^{\circ}C$ $T_{vj}=150^{\circ}C$	E_{on}	65.9 91.1 100.6		
关断损耗能量 (每脉冲) Turn-off energy loss per pulse	$I_C=300A, V_{CE}=900V$ $V_{GE}=\pm 15V, R_G=3.3\Omega$ $du/dt=5500V/\mu s(T_{vj}=150^{\circ}C)$ (电感负载) / (inductive load)	$T_{vj}=25^{\circ}C$ $T_{vj}=125^{\circ}C$ $T_{vj}=150^{\circ}C$	E_{off}	46.1 57.2 59.9		mJ
短路数据 SC data	$V_{GE}\leq 15V, V_{ce}=1000V$ $V_{CEmax}=V_{CES}-L_{sCE}\cdot di/dt$ $t_p\leq 10\mu s, T_{vj}=150^{\circ}C$		I_{sc}	1400		A
结-外壳热阻 Thermal resistance, junction to case	每个 IGBT / per IGBT		R_{thJC}		0.07	K/W
在开关状态下温度 Temperature under switching conditions			$T_{vj op}$	-40	150	$^{\circ}C$

二极管，逆变器 / Diode, Inverter

最大额定值 / Maximum Ratings

Parameter	Conditions	Symbol	Value	Unit
反向重复峰值电压 Repetitive peak reverse voltage	$T_{vj}=25^{\circ}\text{C}$	V_{RRM}	1700	V
连续正向直流电流 Continuous DC forward current		I_F	300	A
正向重复峰值电流 Repetitive peak forward current	$t_p=1\text{ms}$	I_{FRM}	600	A
I^2t 值 I^2t -value	$t_p=10\text{ms}$, $\sin 180^{\circ}$, $T_j=125^{\circ}\text{C}$	I^2t	20000	A^2s

特征值 / Characteristic Values

Parameter	Conditions	Symbol	Value			Unit
			Min.	Typ.	Max.	
正向电压 Forward voltage	$I_F=300\text{A}$, $V_{GE}=0\text{V}$ $I_F=300\text{A}$, $V_{GE}=0\text{V}$ $I_F=300\text{A}$, $V_{GE}=0\text{V}$	$T_{vj}=25^{\circ}\text{C}$ $T_{vj}=125^{\circ}\text{C}$ $T_{vj}=150^{\circ}\text{C}$	V_F	2.07 2.37 2.35	2.80	V
反向恢复峰值电流 Peak reverse recovery current	$I_F=300\text{A}$ $-di_F/dt=2500\text{A}/\mu\text{s}$ ($T_{vj}=150^{\circ}\text{C}$) $V_R=900\text{V}$, $V_{GE}=-15\text{V}$	$T_{vj}=25^{\circ}\text{C}$ $T_{vj}=125^{\circ}\text{C}$ $T_{vj}=150^{\circ}\text{C}$	I_{RM}	141 166 179		A
恢复电荷 Recovered charge	$I_F=300\text{A}$ $-di_F/dt=2500\text{A}/\mu\text{s}$ ($T_{vj}=150^{\circ}\text{C}$) $V_R=900\text{V}$, $V_{GE}=-15\text{V}$	$T_{vj}=25^{\circ}\text{C}$ $T_{vj}=125^{\circ}\text{C}$ $T_{vj}=150^{\circ}\text{C}$	Q_r	42.16 72.90 81.63		μC
反向恢复损耗（每脉冲） Reverse recovered energy	$I_F=300\text{A}$ $-di_F/dt=2500\text{A}/\mu\text{s}$ ($T_{vj}=150^{\circ}\text{C}$) $V_R=900\text{V}$, $V_{GE}=-15\text{V}$	$T_{vj}=25^{\circ}\text{C}$ $T_{vj}=125^{\circ}\text{C}$ $T_{vj}=150^{\circ}\text{C}$	E_{rec}	23.16 41.38 46.06		mJ
结-外壳热阻 Thermal resistance, junction to case	每个二极管 / per diode	R_{thJC}			0.14	K/W
在开关状态下温度 Temperature under switching conditions		$T_{vj\text{op}}$	-40		150	$^{\circ}\text{C}$

负温度系数热敏电阻 / NTC-Thermistor

特征值 / Characteristic Values

Parameter	Conditions	Symbol	Value			Unit
			Min.	Typ.	Max.	
额定电阻值 Rated resistances	$T_c=25^{\circ}\text{C}$, $\pm 5\%$	R_{25}		5.0		k Ω
B-值 B-value	$\pm 2\%$	$B_{25/50}$		3375		K

模块 / Module

Parameter	Conditions	Symbol	Value			Unit
绝缘测试电压 Isolation test voltage	RMS, f=50Hz, t=1min	V_{ISOL}	4000			V
内部绝缘 Internal isolation			Al_2O_3			
储存温度 Storage temperature		T_{stg}	-40		125	$^{\circ}\text{C}$
模块安装的扭矩 Mounting torque for modul mounting		M	3.0		6.0	Nm
端子联接扭距 Terminal connection torque		M	3.0		6.0	Nm
重量 Weight		W		342		g



图 1. 典型输出特性 ($V_{GE}=15V$)
Figure 1. Typical output characteristics ($V_{GE}=15V$)



图 2. 典型输出特性 ($T_{vj}=150^{\circ}C$)
Figure 2. Typical output characteristics ($T_{vj}=150^{\circ}C$)

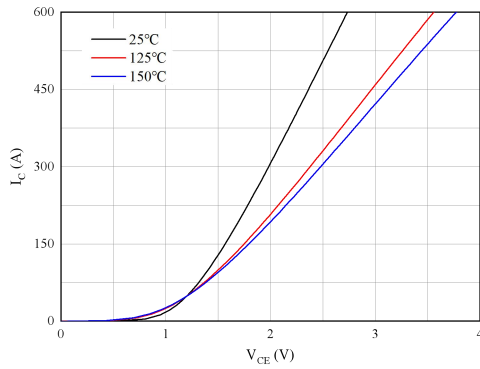

图 3. 典型传输特性 ($V_{CE}=20V$)
Figure 3. Typical transfer characteristic ($V_{CE}=20V$)

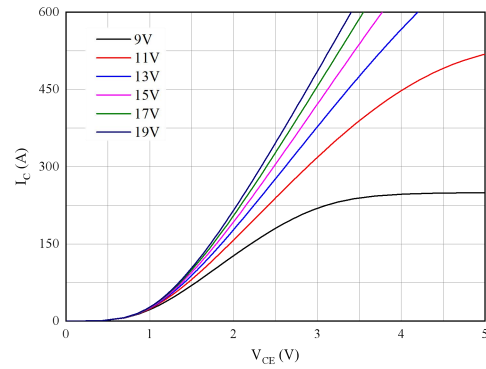

图 4. 正向偏压特性 二极管
Figure 4. Forward characteristic of Diode

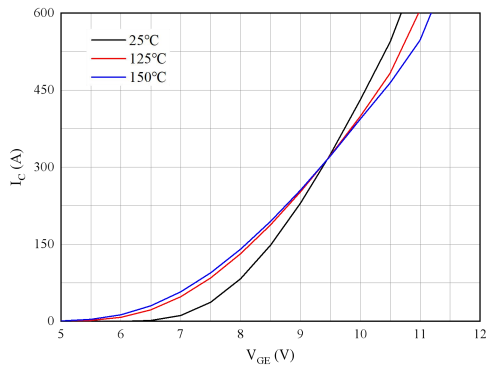

图 5. 开关损耗 逆变器
Figure 5. Switching losses of IGBT
 $V_{GE}=\pm 15V, R_{Gon}=3.3\Omega, R_{Goff}=3.3\Omega, V_{CE}=900V$

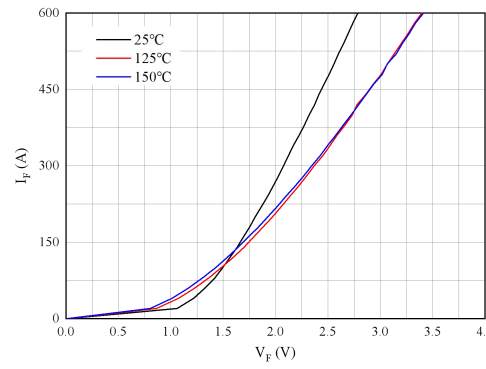

图 6. 开关损耗 逆变器
Figure 6. Switching losses of IGBT
 $V_{GE}=\pm 15V, I_c=300A, V_{CE}=900V$

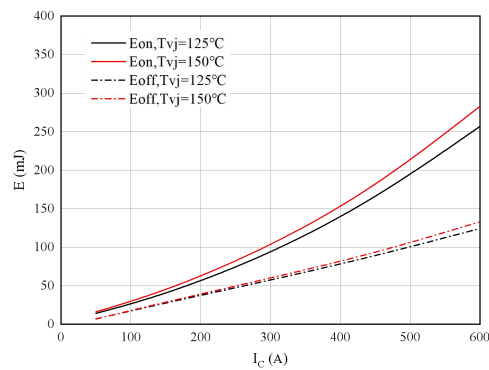

图 7. 开关损耗 二极管
Figure 7. Switching losses of Diode
 $R_{Gon}=3.3\Omega, V_{CE}=900V$

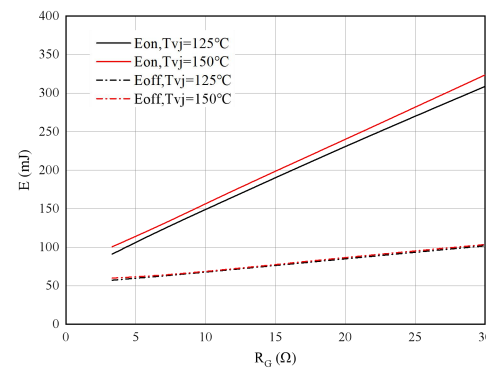

图 8. 开关损耗 二极管
Figure 8. Switching losses of Diode
 $I_F=300A, V_{CE}=900V$

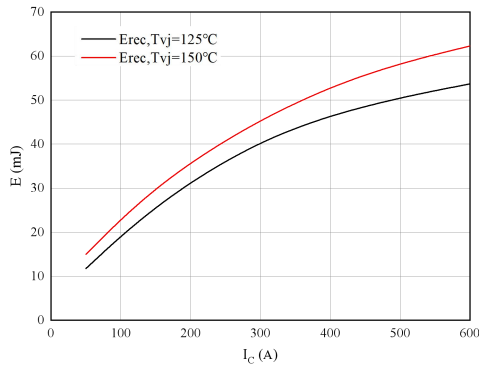

图 9. 电容特性
Figure 9. Capacitance characteristic

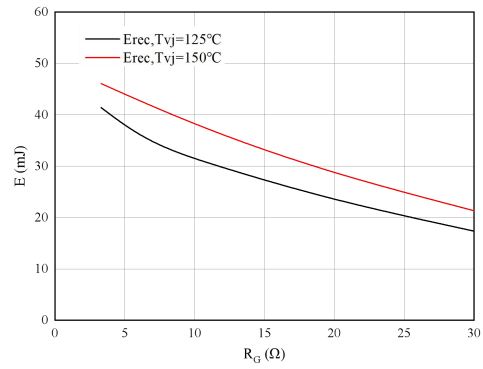

图 10. 负温系数热敏电阻 温度特性
Figure 10. NTC-Themistor-temperature characteristic

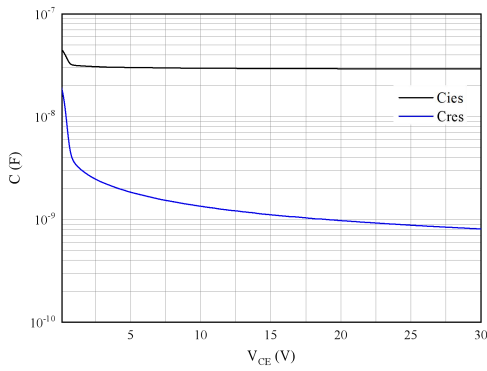

图 11. 瞬态热阻抗 IGBT 逆变器
Figure 11. Transient thermal impedance IGBT, Inverter
 $Z_{thJC}=f(t)$

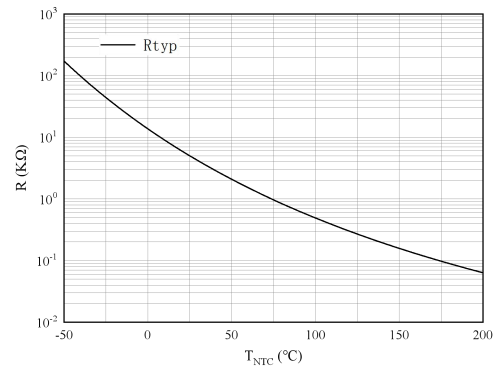

图 12. 瞬态热阻抗 FRD 逆变器
Figure 12. Transient thermal impedance FRD, Inverter
 $Z_{thJC}=f(t)$

接线图 / Circuit diagram

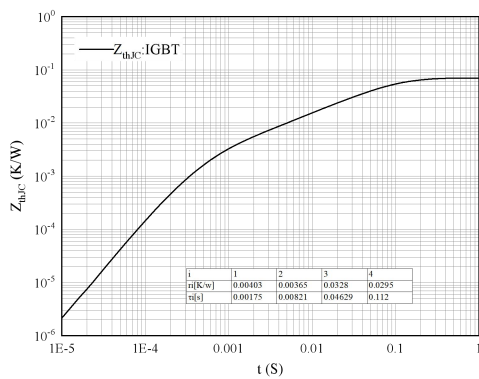

封装尺寸 / Package outlines

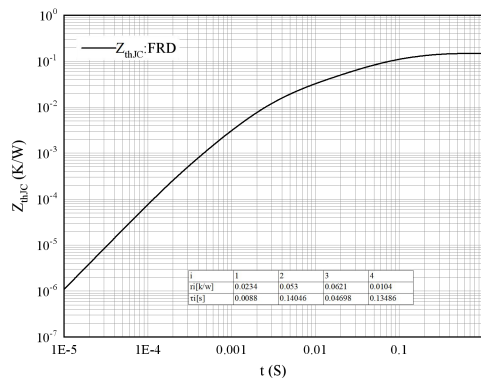
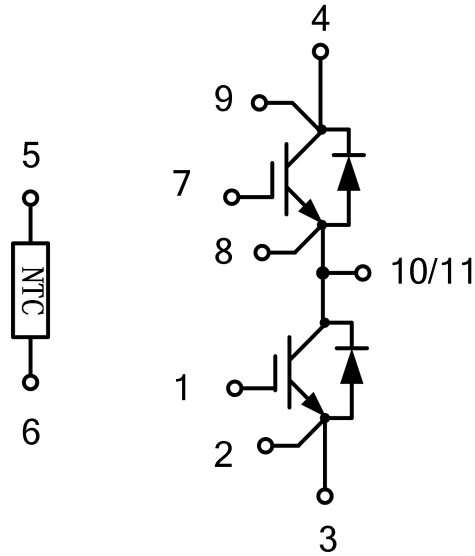